



CHELT THERAPY

 Mectronic

INNOVATION IS OUR MISSION

Since 1986 Mectronic designs and manufactures devices for physical therapy, and by producing over 20000 laser systems it is leading know-how and experience in the field of therapeutic lasers.

From the earliest surgical laser and CO₂ laser, Mectronic has reached important goals, the result of collaboration between its own team and research centers, universities, national and international institutes. Mectronic has always distinguished itself in technological innovation, anticipating for years the main technical and applicative uses of the laser for therapeutic purposes: from the first use of Nd: YAG laser in therapeutic mode, to the use of semiconductor laser sources, from the first laser with three wavelengths, up to the first 1064nm broadband semiconductor laser system, therapeutically more effective and with low energy consumption.

From then until now, this process has led to the development of new more efficient therapies, with new features and guaranteed results.

The latest innovation in the Mectronic home is the ultimate **CHELT Therapy**, the unique and innovative synergy between the THEAL lasertherapy and the cryotherapy with dry air at -30°C with thermal control.

CHELT Therapy is a unique, exclusive, safe, effective and patented technique.

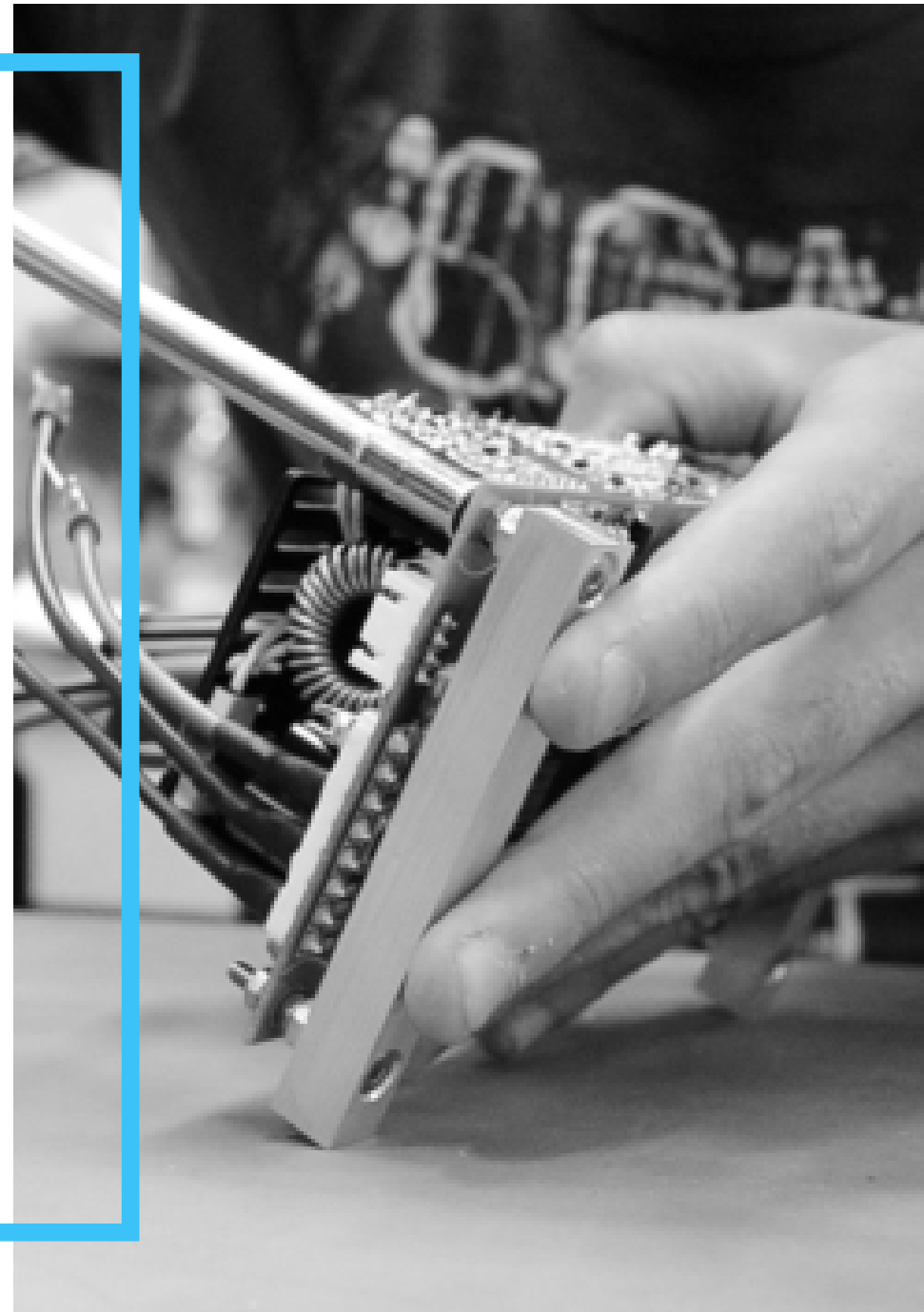



OUR PARTNERS IN SPORTS

Numerous sports medicine professionals use the methodics developed by Mectronic to obtain excellent results in muscle recovery and athlete rehabilitation. From preventive care, to first athletic aids, to the rehabilitation and reintegration of the athlete, Mectronic offers the best therapies for its champions.



Fornitore Ufficiale
2023/24





WHAT IS CHELT THERAPY?

CHELT Therapy (Cryo High Energy Laser Therapy) is the innovative synergy between cryotherapy with dry cold air at -30°C with thermal control and THEAL laser therapy, which maximizes the therapeutic results in both acute and chronic phases.

The dry cold air produced by the Cryo module is the carrier for THEAL lasertherapy: the produced vasoconstriction favours an excellent laser diffusion in depth. CHELT Therapy is ideal for solving musculoskeletal disorders and for combating inflammation and hematomas.

CHELT Therapy is an innovative synergy, unique, fast, effective, safe and performing.

THE BEST FOR YOUR PATIENTS

The results of CHELT Therapy are scientifically proven by research conducted at prestigious universities. In clinical studies, it appears that, for 98% of the patients, the pain diminishes immediately and significantly from the first session.

98% ^{*} of patients treated with CHELT Therapy try immediate relief from the pain.

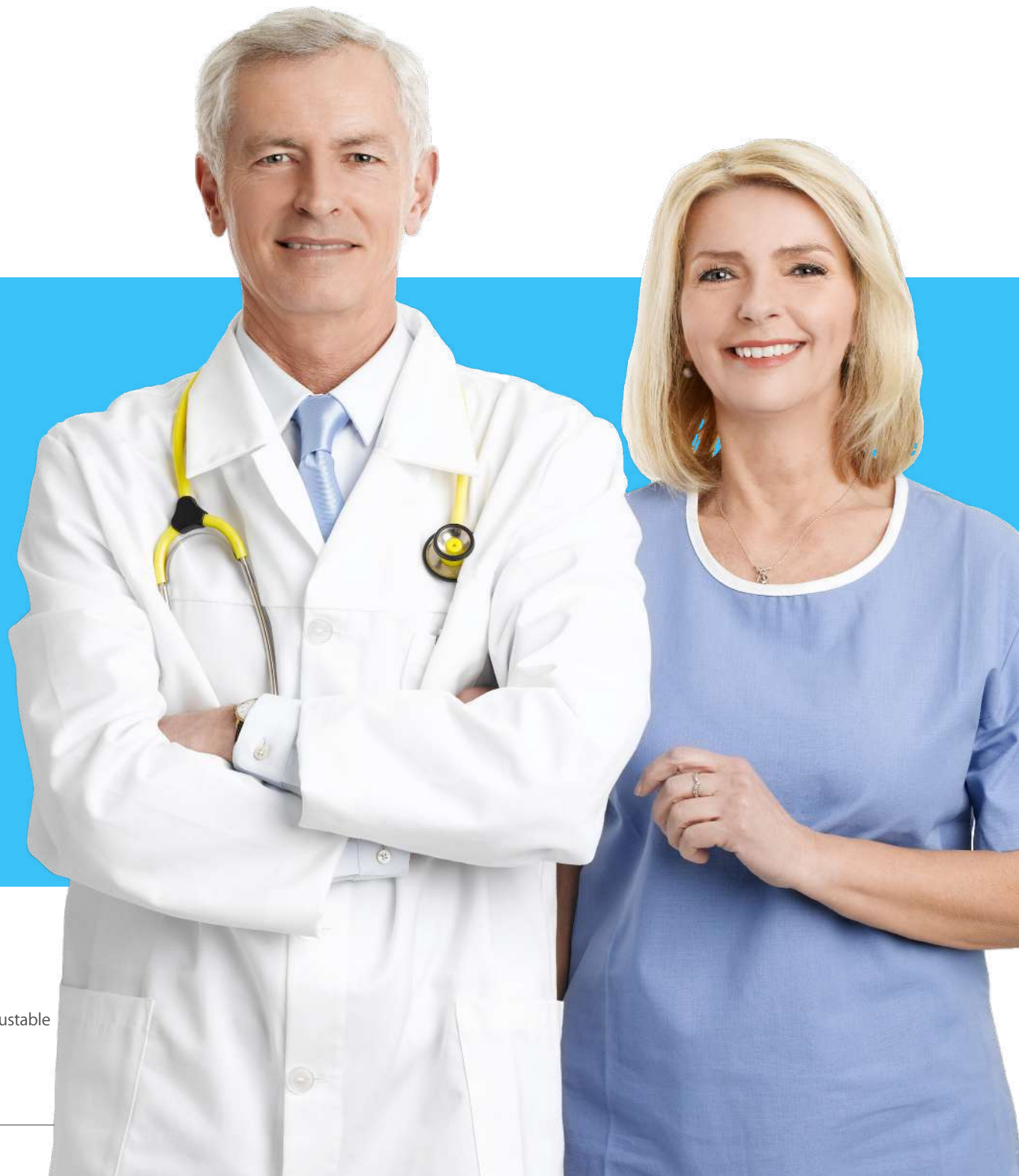

*Short-term effect of Shockwave Therapy, Temperature controlled High Energy Adjustable multi-mode emission Laser (THEAL Therapy) or stretching in Dupuytren's disease: a prospective randomized clinical trial.

*CHELT Therapy in the Treatment of Chronic Insertional Achilles Tendinopathy

WHAT ARE THE APPLICATION FIELDS?

CHELT Therapy is a totally adaptive and customizable method; For this reason its fields of application are many. CHELT Therapy is the solution required by different types of operator to solve many pathological conditions.

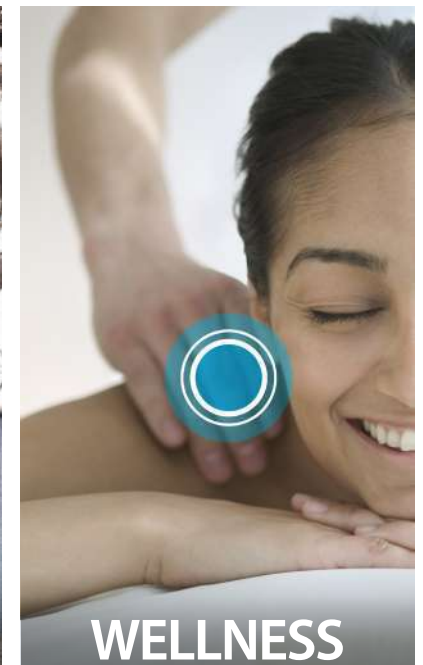

THE THERAPY OF CHAMPIONS

CHELT Therapy is the innovative therapeutic method that, thanks to the powerful and high-performance synergy between the innovative THEAL phototherapy and dry air cryotherapy with thermal control, becomes the ideal ally in the daily practice of both clinics and best sports clubs. Thanks to immediate and long-lasting results, CHELT Therapy is the ideal partner to solve the pathologies of the champions.



SCIENTIFIC RESEARCH

Mectronic collaborates with various institutes and universities, in order to validate the beneficial effects of the developed therapeutic methods. The scientific research staff aims to deepen the therapeutic application of different biophysical stimuli in musculoskeletal disorders. In particular, in the face of a progressive wide-scale clinical use of high-tech therapies, scientific research is almost completely lacking in studies of specific clinical trials. For this reason, prospective randomized clinical trials have been launched to verify the short-term and long-term clinical effects of CHELT Therapy.

The following Scientific Research was published to demonstrate the effectiveness of CHELT Therapy:

1_ *"CHELT therapy in the treatment of chronic insertional achilles tendinopathy"*

Notarnicola A, Maccagnano G, Tafuri S, Forcignanò MI, Panella A,

Moretti B.- Epub 2013 Dec 19

Scientific research carried out on 60 patients subjected to achilleus tendinitis, which demonstrated rapid and long-lasting benefits of CHELT Therapy: monitoring the level of pain before and after the sessions, through the VAS scale, after 2 months of treatments and exercises, it is noted that CHELT Therapy is extremely effective in the treatment of achilleus tendinopathies. Cryotherapy combined with THEAL laser therapy gave immediate relief from pain, ensuring to the patient a complete functional recovery.

2_ *"Temperature controlled high energy adjustable multi-mode emission laser therapy (THEAL) for the treatment of lower back pain: clinical efficacy and comparison of different wavelengths"*

Notarnicola Angela, Covelli Ilaria, Fiore Alessandra, Fari Giacomo,

Megna Marisa, Moretti Biagio (Bari)

This study, conducted on 60 patients, showed the efficacy of THEAL THERAPY: by analyzing the level of pain, through the VAS scale, the Oswestry Score and the Roland Scale before the treatment, at the end of the session cycle and at a distance of 1, 2 and 4 months, it was noted that THEAL THERAPY is extremely effective in treating hernias and lumbar pain. The pain decreases immediately after the first session and at the end of the session cycle and the benefits persist for months. THEAL THERAPY is a valuable ally in the treatment of hernias, discopathies and lumbar pain, thanks to its innovative selective polymodal emission, it provides immediate, effective and safe results.

A close-up photograph of intricate, white, needle-like ice crystals against a dark blue background. The crystals are sharp and layered, resembling a microscopic view of snow or frost. A white rectangular box is overlaid on the right side of the image, containing text.

CHELT THERAPY: A UNIQUE SYNERGY

The supply of dry cold air at -30°C , with thermal control, of CHELT Therapy blocks the extravasation and vasodilatation of the capillaries due to the mediators of the inflammation, avoids the hematomas, has a high and immediate analgesic effect and allows an early treatment with THEAL lasertherapy in order to maximize therapeutic performance.

CHELT CRYOTHERAPY: THE CARRIER FOR THEAL LASER THERAPY

The dry cold air at -30°C is the carrier for THEAL phototherapy, it slows down the cellular metabolism and the blood flow, prevents the calcification of the edemas and through the blockage of the extravasation allows an early instrumental investigation of the trauma.

The superficial vasoconstriction inhibits the flow of oxygenated hemoglobin, chromophore for the laser radiation, and consequently allows the continuous attainment of the deepest layers of the tissues, favouring the penetration of the laser beam.

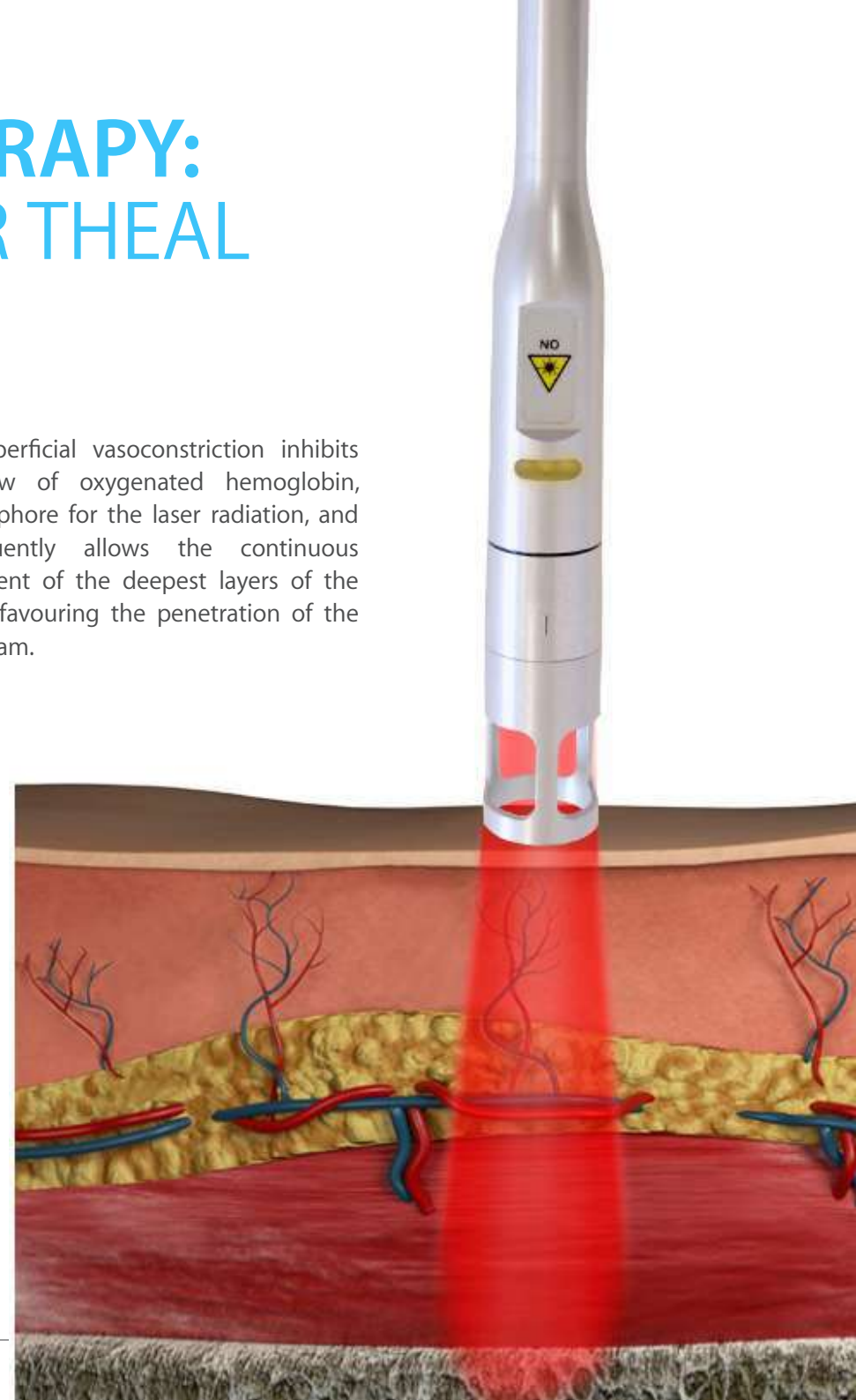
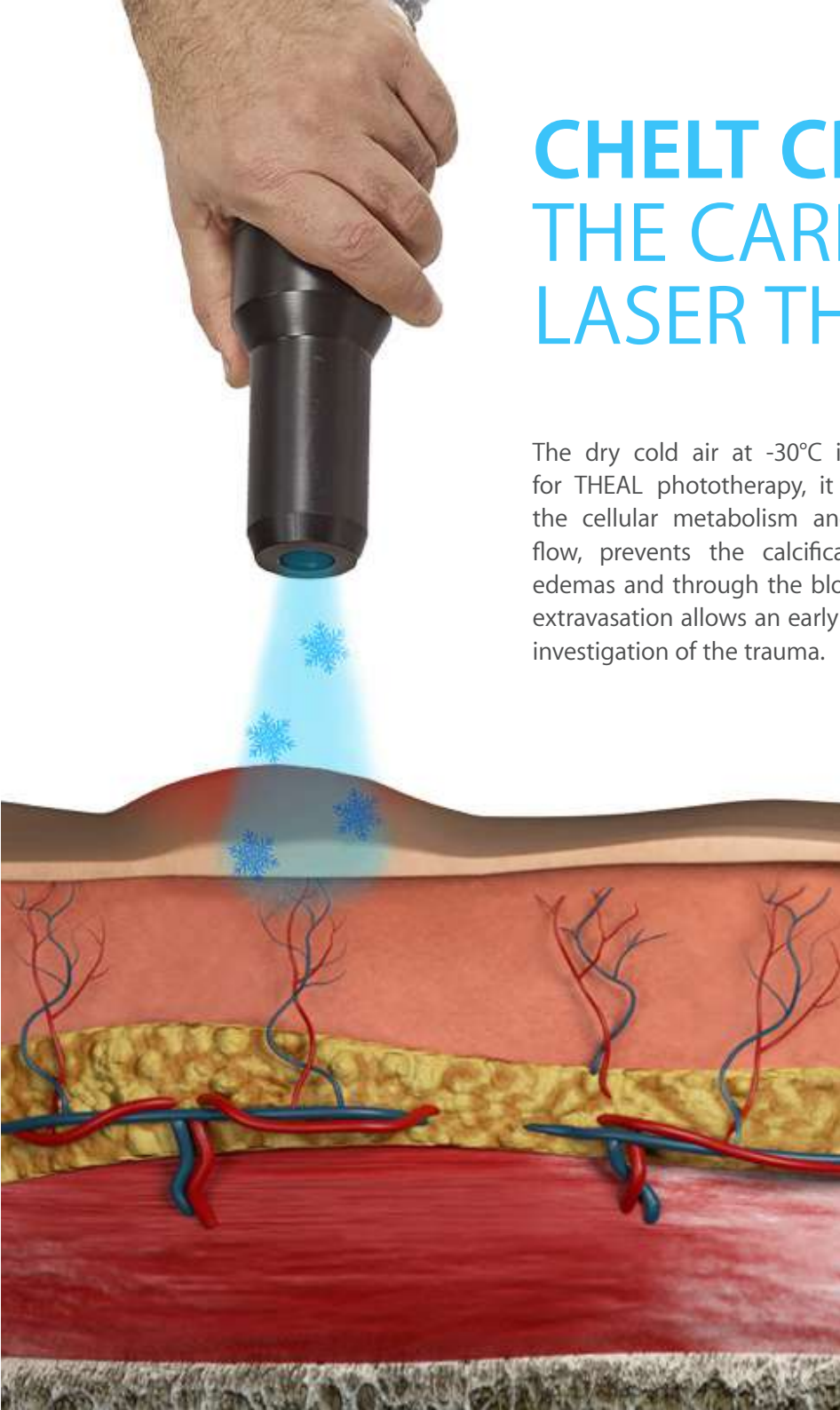

AMPLIFIES PHOTOBIO-MODULATION WITH CHELT THERAPY

Photobiomodulation of biological tissues requires the administration of high energy doses in order to maximize tissue regeneration and physical recovery. The high energy doses cause a vasodilation that increases the flow of hemoglobin, chromophore for laser radiation, decreasing the depth of action of lasertherapy. The micro-sessions

of dry cold air cryotherapy at -30°C rapidly induce a strong vasoconstriction that inhibits the flow of oxygenated hemoglobin and allows THEAL lasertherapy to reach the deepest layers of the tissues, favouring penetration and photobiomodulation.

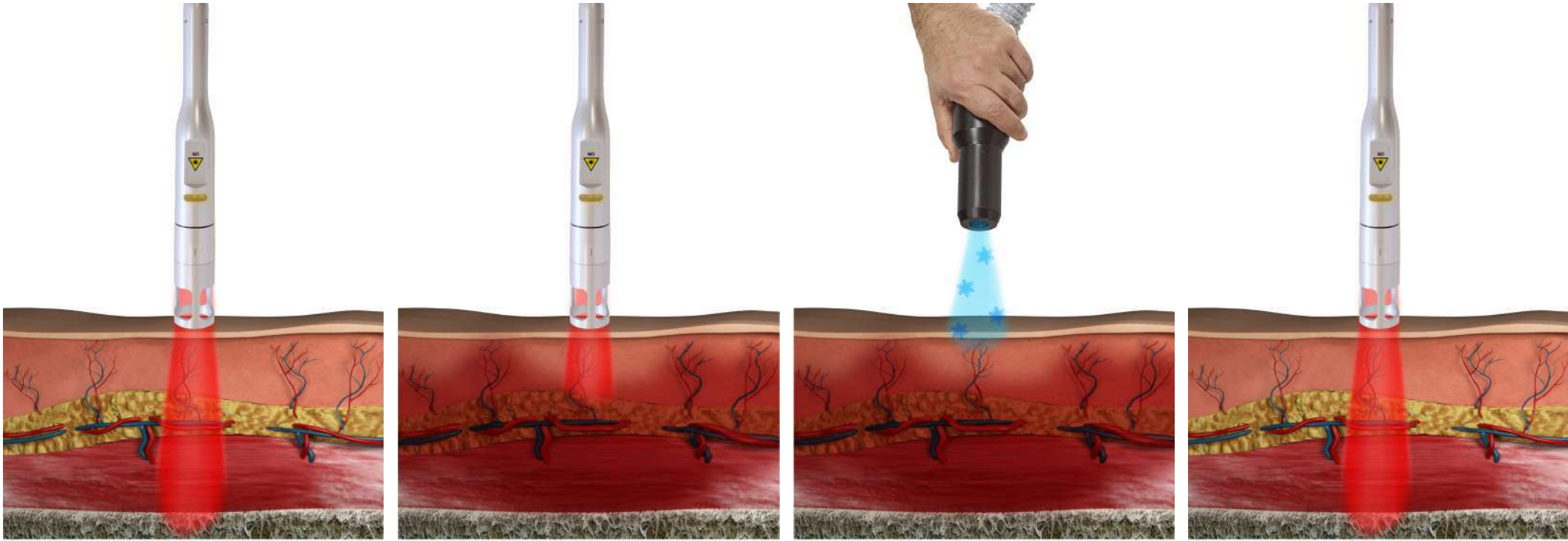

INNOVATIVE THERMAL SHOCK

CHELT therapy, thanks to the synergy between cryotherapy with dry cold air at -30°C and THEAL lasertherapy and thanks to the patented temperature control system of the tissues, allows to generate a very performant thermal stress.

The thermal stress, generated by a subsequent passage of the tissues from a hypothermic, naturally thermal and finally hyperthermal state, causes an activation of the microcirculation and a neoangiogenesis, the first indispensable phase of photobiomodulation, that assures the natural evolution of the regenerative therapeutic processes.

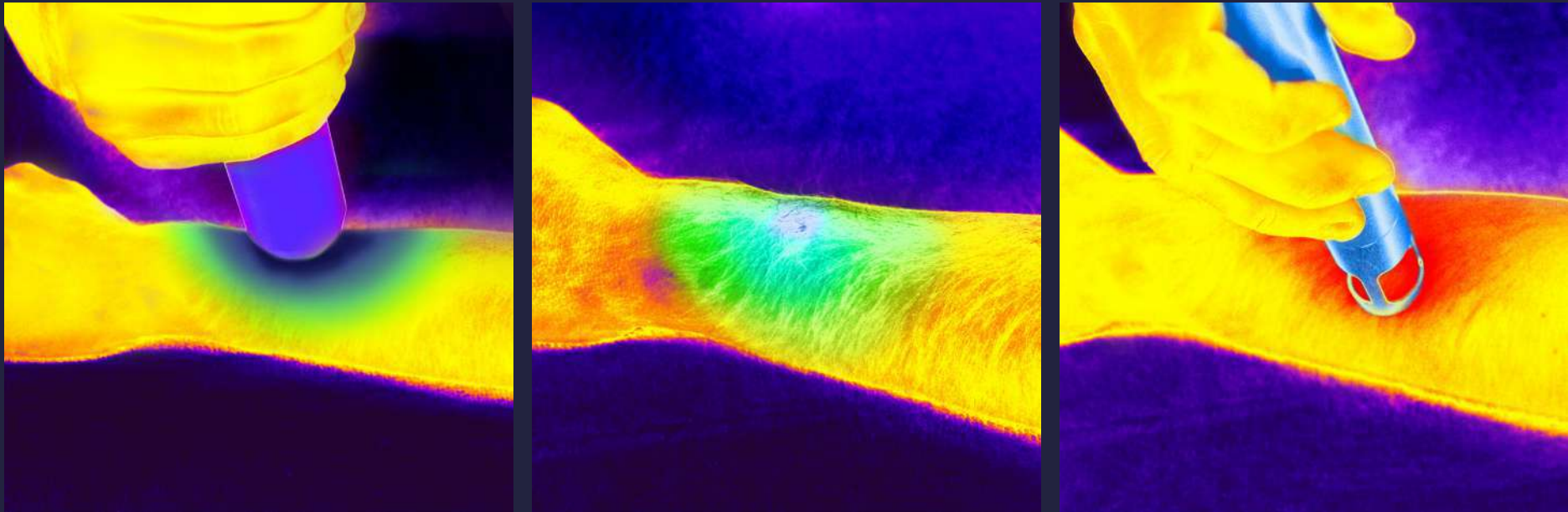

The background of the slide is a microscopic view of several cells, likely fibroblasts or epithelial cells, showing their nuclei and internal organelles. The cells are rendered in shades of blue and cyan against a dark background. A large, semi-transparent white rectangular box is positioned on the right side of the slide, containing the main text.

UNLOCKING THE BODY'S OWN **HEALING** POTENTIAL

The luminous energy of **CHELT Therapy** allows to interact with biological tissues by triggering the metabolic reactions necessary to accelerate the process of natural healing. The CHELT Photon Therapy, when interacting with biological tissues, releases their energy to the cells by allowing the chromophores to transform it into other forms of energy to support **photobiomodulation** at the base of all the metabolic processes.

The **photobiomodulation**, at the base of the metabolic activities, is triggered by the **selective absorption** and **naturally thermal** laser light that allows to obtain three basic effects: **tissue regeneration**, **modulation of the inflammatory action** and **analgesic effect**.



THE KEY OF THE NEW PHOTOTHERAPY

All devices capable of implementing CHELT Therapy allow you to emit red laser light at **650nm** with a power of **2W (2000mW)**. The wavelength 650nm represents a very good compromise between depth of action, photon energy and selective absorption by the main chromophore of the cell photobiomodulation, **Cytochrome C Oxidase**.

The laser light at 650nm while being primarily absorbed by the melanin, provides a significant energy exchange at a superficial level and average depth favoring an effective biomodulant effect. It also inhibits bacterial proliferation and promotes cell growth, enabling incredible results in healing **wounds, lesions and ulcers**. The high number of studies and scientific research conducted using this wavelength confirms its extreme effectiveness.

“Low-Level Laser Therapy Enhances Wound Healing in Diabetic Rats: A Comparison of Different Lasers”
FAROUK A.H. AL-WATBAN

A SYNERGISTIC ACTION WITHOUT PRECEDENT

The ability of the laser light to penetrate deep is certainly very important, but not sufficient, indeed, as the first law of photochemistry "**Light must be absorbed before photochemistry can occur**"; is much more important the ability of the laser light to interact and to be absorbed by biological tissues.

All wavelengths within the therapeutic window (**600nm - 1100nm**) allow to interact with biological tissues by triggering photobiomodulation processes, but it has been shown that some of them are definitely more effective. It is scientifically proven that the main cellular chromophore of photobiomodulation is the **Cytochrome C oxidase**, an enzyme present within the mitochondria, cellular organelles present

within each cell of the human body.

Numerous recent scientific articles like "Re-evaluation of the near infrared spectra of mitochondrial cytochrome c oxidase: Implications for non invasive in vivo monitoring of tissues" (G.Mason, P. Nicholls, E. Cooper – 2014) and "Multiple Roles of Cytochrome c Oxidase in Mammalian Cells Under Action of Red and IR-A Radiation"(T. Karu - 2010) have demonstrated that the laser light in the visible red, such as that at **650nm**, and the laser light in the range of **800nm - 850nm**, are those most absorbed by the Cytochrome C Oxidase, enabling to trigger the photobiomodulation in the best possible way.

CHELT
THERAPY

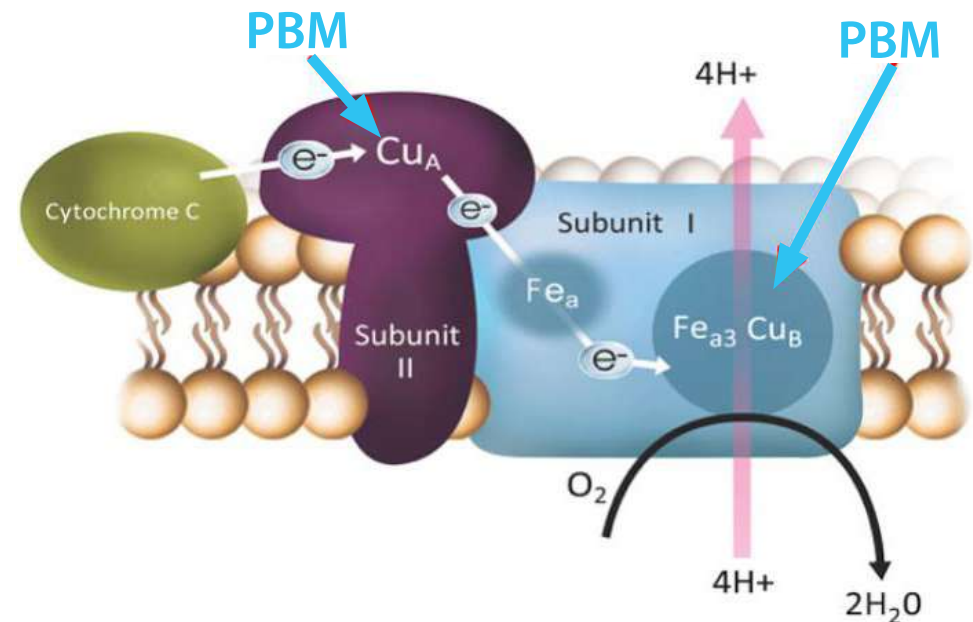
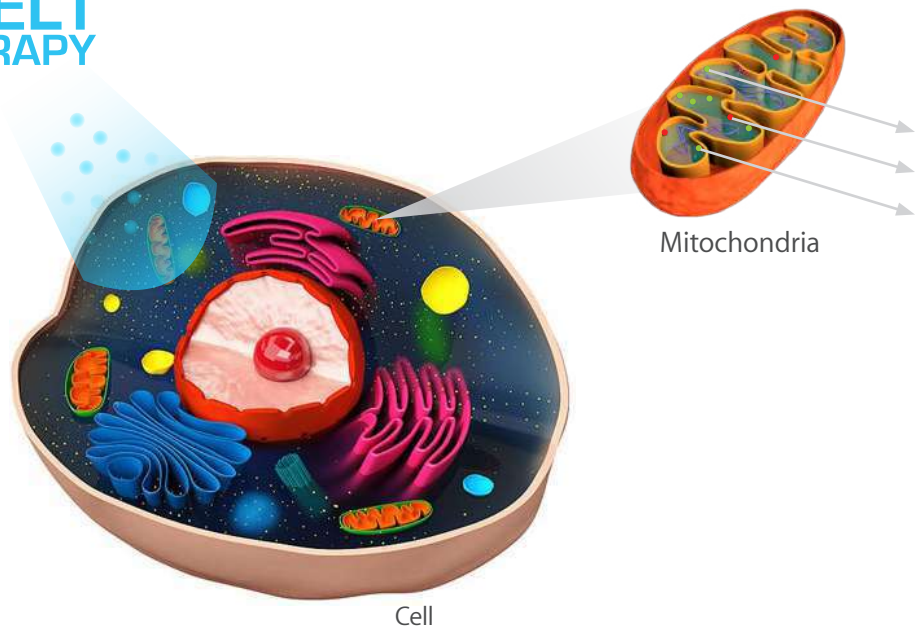

“LIGHT MUST BE ABSORBED BEFORE PHOTOCHEMISTRY CAN OCCUR”

Between the wavelengths emitted by the main devices for CHELT Therapy there are also **980nm** and **1064nm**. These two wavelengths while being less absorbed by the **Cytochrome C Oxidase** have other features which maximize the therapeutic results triggered by photobiomodulation.

Both wavelengths, in particular the **980nm**, are absorbed by the water and allow to generate both a good photothermal effect and an excellent photomechanical effect when the emission is characterized by pulse trains.

In addition, the **1064nm** wavelength, thanks to its greater depth of action than the **980nm** and the smaller **scattering**, has more directional action and greater power density at the same power level.

The **980nm** and **1064nm** wavelengths allow to optimize the action on the thermal and mechanical receptors and, when combined with the **E²C** mode, ensure the right interaction with the peripheral nervous system, activating the Gate Control mechanism for a quick analgesic effect.

Due to these peculiarities, these two wavelengths trigger further metabolic pathways that may act in some cases at the same time as those triggered by photobiomodulation.

CHELT Therapy not only has all the wavelengths necessary to trigger **photobiomodulation** and **action on the thermal and mechanoreceptors**, but allows them to be **synergized** and **uncompetitive** between them, and to associate with each wavelength different emission modes, in order to maximize the therapeutic result for the specific patient and the specific pathology.

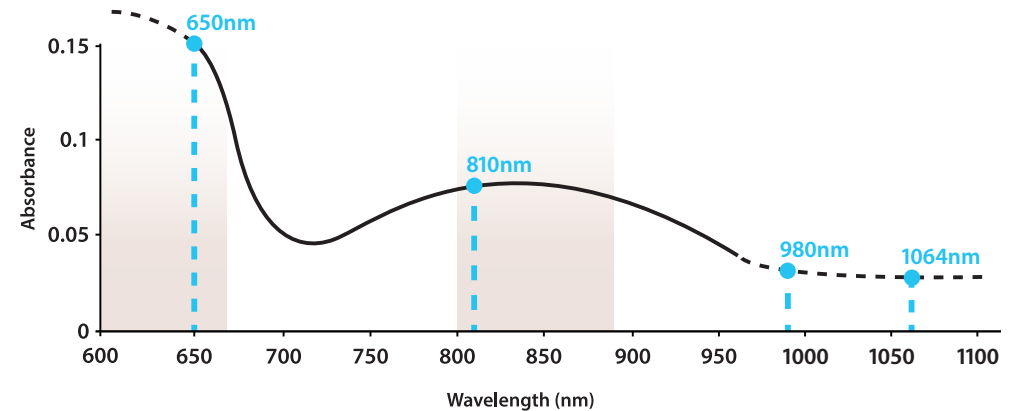

“Re-evaluation of the near infrared spectra of mitochondrial cytochrome c oxidase: Implications for non invasive in vivo monitoring of tissues” (2014) G.MASON, P. NICHOLLS, E. COOPER

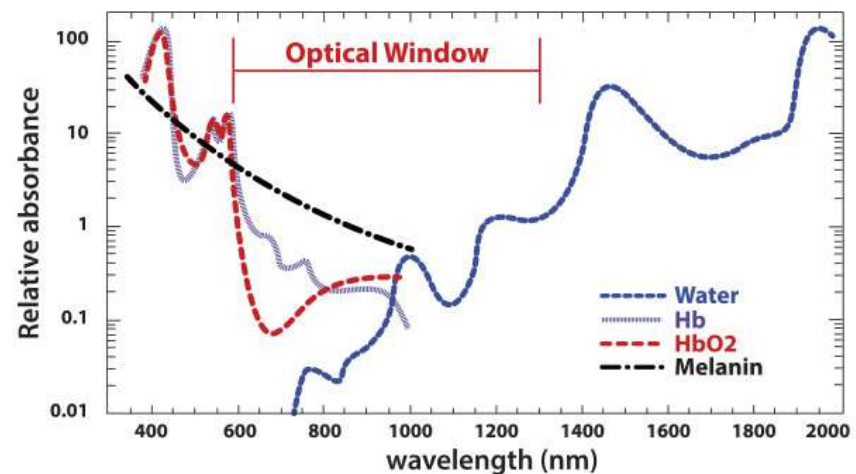

“Mechanisms of low level light therapy” (2006) M. HAMBLIN, T. DEMIDOVA



THERAPY OF INFINITE POSSIBILITIES

CHELT Therapy has been designed on the basis of all the most recent and important scientific researches on phototherapy and for this reason is equipped with the fundamental wavelengths to trigger the photobiomodulation and the action on the thermo and mechanoreceptors and allowing to mix them in order to adapt to the patient and the specific pathology.

It is also equipped with multiple emission modes, a wide range of applicators and thermal control of biological tissues in order to maximize compliance and therapeutic results.

Thanks to the synergy between THEAL adaptive phototherapy and dry cold air cryotherapy at -30°C with thermal control of CHELT Therapy, it is possible to maximize the therapeutic performance on patients with different physiopathological characteristics and with acute or chronic pain, edemas, lesions, wounds and musculoskeletal pathologies.

CHELT Therapy: Healing with the support of the light



NO MORE LIMITS WITH CHELT THERAPY

Power plays a key role in the therapeutic laser action on biological tissues.

CHELT Therapy not only delivers laser light at different intensity but enhances its potentiality and effectiveness by allowing the operator to emit from very low energy levels to high intensity.

This revolutionary and unique method represents the meeting point for Low Level Laser Therapy (LLLT) and high intensity laser therapy.

Thanks to this flexibility of work, the operator can treat different pathologies in different modes with different applicators.

There are no frontiers anymore, thanks to CHELT Therapy.

UP TO 8 WAVELENGTHS

For the therapist, it is crucial to have the choice between different wavelengths depending on one's needs. In fact, each wavelength has different diffusion and absorption properties in different biological tissues and interacts with biological tissues in a distinct way, triggering various chemical-physical reactions.

With CHELT Therapy it is possible to combine 4, 6 and 8 wavelengths mixes in one device: in fact, thanks to the new technology, the operator has available a range of wavelengths never seen before. With this range of possibilities, it is safe to treat best the acute and chronic problems of patients.

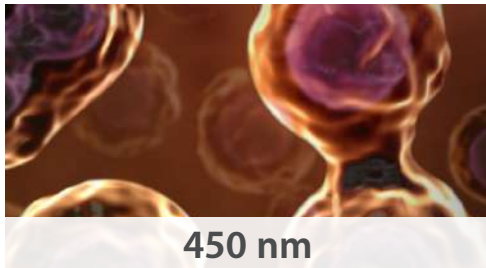

Highly absorbed by hemoglobin and its absorption by melanin is greater compared to the infrared laser light. It also has an excellent bactericidal effect and has excellent dental, surgical and vascular applications.

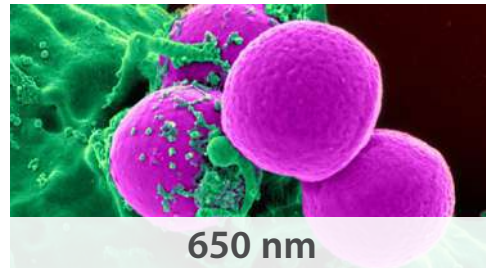

Absorbed mainly by melanin, it guarantees a remarkable energy exchange at the surface level and in the medium depth. It also inhibits bacterial proliferation and promotes cell growth, allowing to achieve amazing results in treating wounds, sores and ulcers.



Its absorption enables the oxidative process of hemoglobin to accelerate the production of ATP. This wavelength has proven its effectiveness scientifically in nerve regeneration.

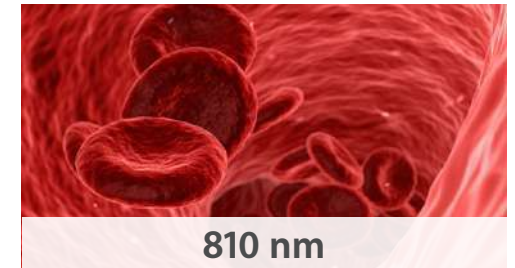

It enables rapid activation of the oxidative hemoglobin process, accelerating the production of ATP. Moving the right energy supply to the muscles and tendons aids tissue regeneration.

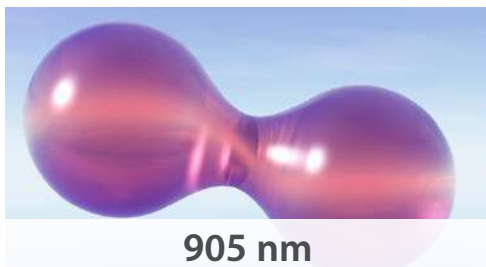

This wavelength is partially absorbed by water, hemoglobin, melanin and cytochrome C oxidase and it allows to accelerate the natural healing processes.



Mainly absorbed by water, it allows to optimize the action on thermoreceptors and mechanoreceptors. When combined with E²C mode, it ensures the right interaction with the peripheral nervous system, activating the Gate Control mechanism for a rapid analgesic effect.

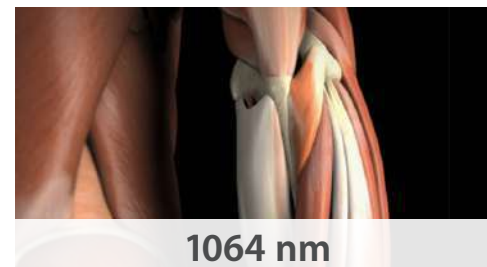

Its high directionality allows to convey the correct dose of energy directly to the noxa. The result is a perfect synergy that harmonizes the rapid analgesic effect with a control of inflammatory processes and the deep activation of vital metabolic processes for all cellular activities.



Highly absorbed by water. The energy transmitted by laser therapy will be converted into heat. Deep tissue layers become localized heat points, creating cellular thermal gradients that stimulate cellular microcirculation and oxygenation.

A PERSONALIZED MIX

CHELT Therapy not only offers a wide range of wavelengths, but also allows you to create totally custom mixes, modifying energy declinations and interacting with biological tissues for safe and accurate therapy as never seen before.

Before now the wavelength mix was fixed and could not be changed, today the control is in your hands with the **Lambda Mixer**.

This innovative system allows the operator to define the percentage of each wavelength and the emission modes of each of it, creating the most performing mix in order to maximize therapeutic results.

Thanks to CHELT Therapy treatment is extremely safe, effective and efficient.



MIXING EMISSION MODES AND WAVELENGTHS: TODAY IT IS POSSIBLE



In order to treat different patients with different pathologies safely, effectively and immediately, it is essential to customize therapy by defining the correct mix of wavelengths and emission modes.

For this reason, Mectronic has expanded the therapeutic horizons, allowing you to create custom mixes of wavelengths and implementing CHELT Therapy with new emission modes. In a simple and intuitive way, the operator can choose up to 11 emission modes, differentiated for the benefits and characteristics of the laser pulse, ensuring maximum effectiveness and safety for each pathology.

Furthermore, CHELT Therapy allows you to create customized output modes thanks to the innovative and powerful **Wave Creator** system. CHELT Therapy differs from other methods thanks to its ability to adapt and personalize photon energy according to the patient and the pathology to be treated. Thanks to **Lambda Mixer** and **Wave Creator**, CHELT Therapy is an adaptive, safe, unique and performing method.

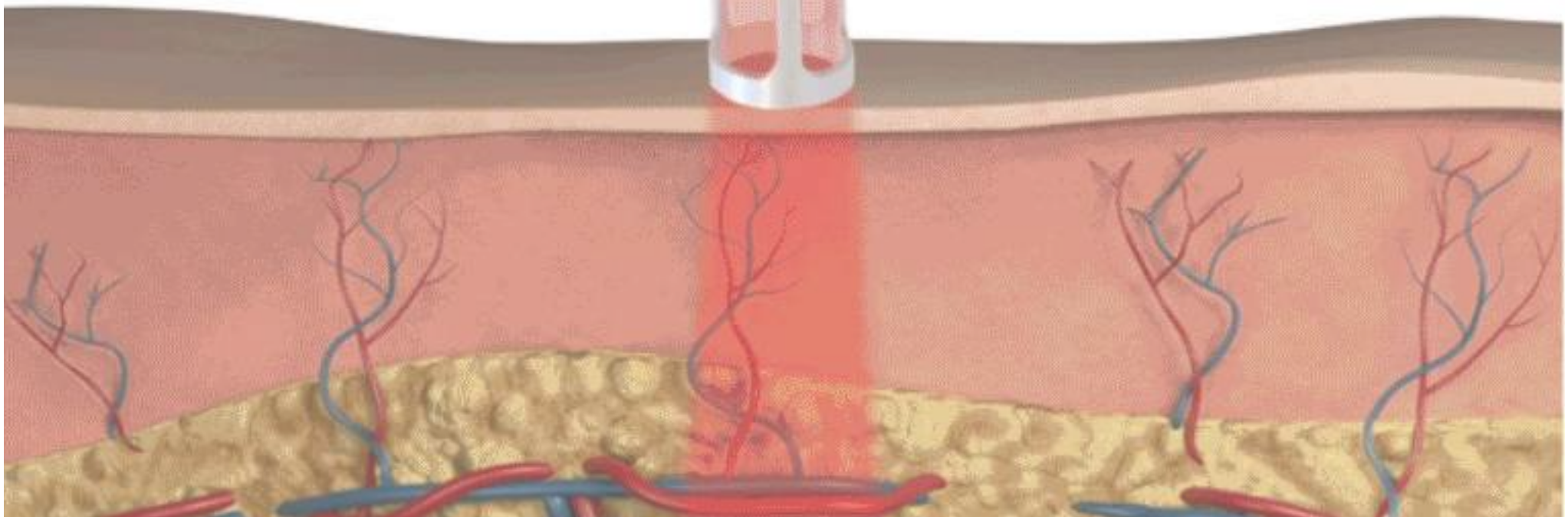

EMISSION MODES BASED ON RESEARCHES

CHELT Therapy, in addition to the advanced Wave Creator system for creating customized emissions, features 11 emission modes designed to maximize photobiomodulation and action on thermo and mechanoreceptors. In particular, it has been shown that the optimal laser emission to trigger photobiomodulation must be continuous or pulsed with a pulse duration of at least a few milliseconds, as Hamblin said in 2010 in the article *"Effect of Pulsing in Low-Level Light Therapy"*

"and a dark period between two pulses between 50ms and 200ms, as stated by T. Karu in 2001 in the article *"Studies on the Action Specifics of a Pulsed GaAlAs Laser ($\lambda = 820\text{nm}$) on a Cell Cultures"*. The main emission modes of the CHELT Therapy meet the criteria needed to trigger photobiomodulation.

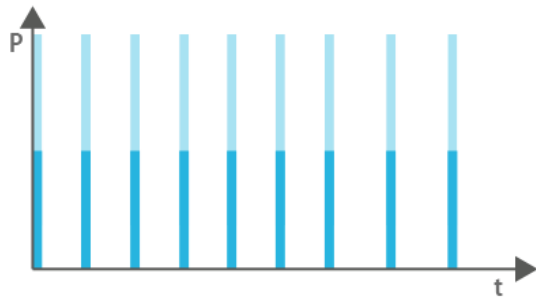

HPM

The High intensity Pulse Mode emits pulses with short duration characterized by high peak power, limiting the thermal effects on the tissues.

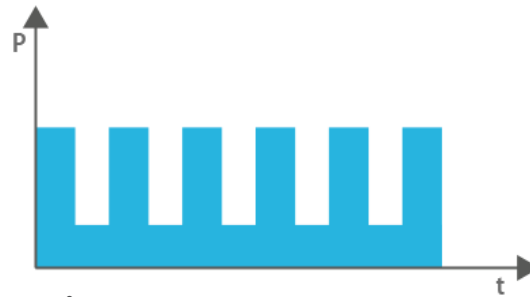

Dimmer

The innovative Dimmer mode permits to combine in a unique emission mode the biostimulant effect of Continuous mode with the analgesic effect of Pulsed mode.

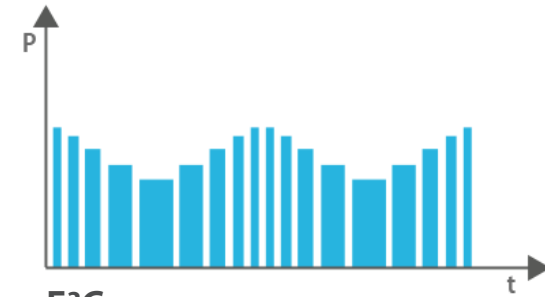

E²C

Generates laser pulses of power, duration and frequency variable; this mode of delivery interacts correctly with the peripheral nervous system generating a fast and long lasting analgesic effect, removing the pain in a fast, safe and performing way.

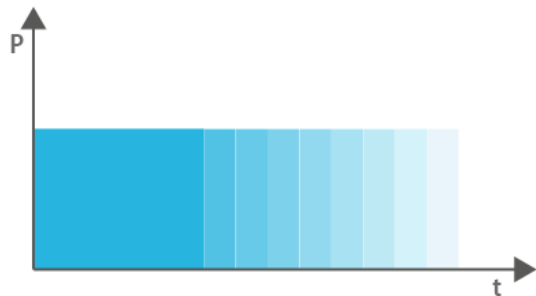

Wave Creator

The operator can save the mode and mix of modes created. Thanks to Wave Creator, therapy is even more flexible and effective.

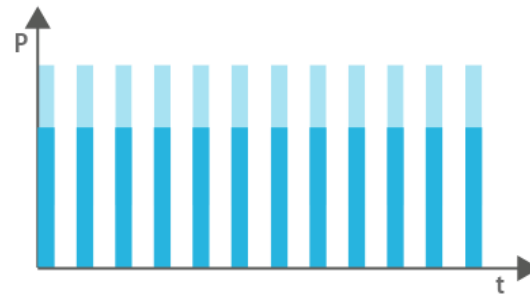

AntInf

Through controlled vasodilation, the process of neoangiogenesis causes the reactivation of lymphatic peristalsis and the collection of catabolites which result from inflammation.



CW

Starts processes of cellular biostimulation, increasing the production of ATP, and accelerating tissue regeneration.

TRADITIONAL MODES

In the wide range of available emission modes, CHELT Therapy preserves the modes that have always been present in Mectronic devices, ensuring continuity with the traditional methods.

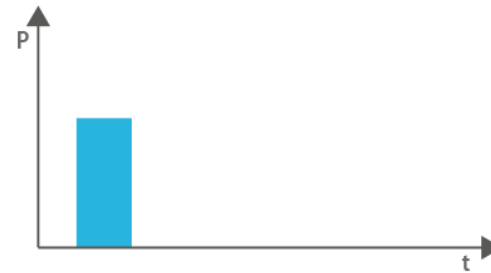

Single Pulse

The laser emission focuses on a single high-energy pulse, the dosage of which is precise and effective. To ensure greater efficiency, the amplitude of the single pulse is adjustable by the operator, so that it always offers targeted action.

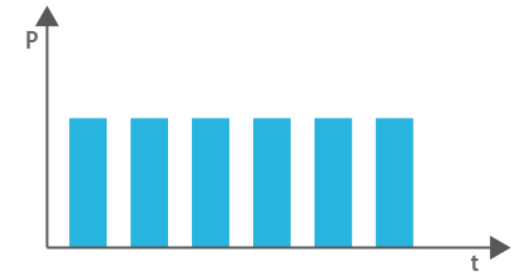

Burst

This mode is particularly indicated in recurrent pathologies where chronic algia is predominant. Pulse sequences allow rapid interarticularis neoangiogenic action and restoration of cellular homeostasis.



Puls 1



Puls 2

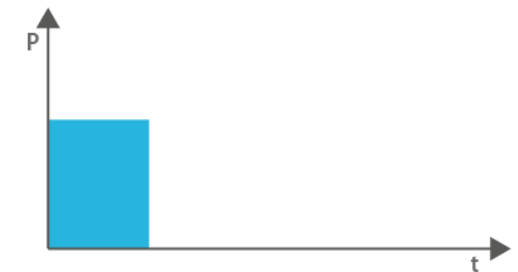

Puls 3

3 Different ways to adapt therapy to the acute phase, optimizing pro and anti inflammatory action, increasing biostimulation with less thermal impact. These modes allow optimization of the laser emission according to the phototype.

SYNERGY E²C – CRYOTHERAPY

The E²C patented stochastic emission generates laser Pulses of power, duration and frequency variable; this particular mode of energy delivery interacts correctly with the peripheral nervous system, generating a fast and long lasting analgesic effect. The combination of the analgesic effect of E²C with the analgesic effect of dry cold air cryotherapy at -30°C allows to remove the pain in a fast, safe and performing way.





TEMPERATURE CONTROL SYSTEM

In order to maximize the therapeutic results and ensure complete control of the therapy making it safe and effective, Mectronic has designed and patented an advanced tissue thermal control system. Thanks to this advanced system, CHELT Therapy is applicable to multiple pathologies of the musculoskeletal system of patients with different phototypes and different tissue types in an effective and safe way, making CHELT Therapy even more unique and close to the needs of operators and patients.



Thanks to four different working modes and the ability to set one to two thermal thresholds, the operator can maximize therapeutic performance in total safety. The intuitive and constant feedback provided by the device and the innovative polychromatic LED system integrated in the handpiece guarantee practicality and high control of the therapy. In addition, thermal control allows treatments within specific thermal thresholds to maximize therapeutic results and activate in the best possible way the **photobiomodulation**.

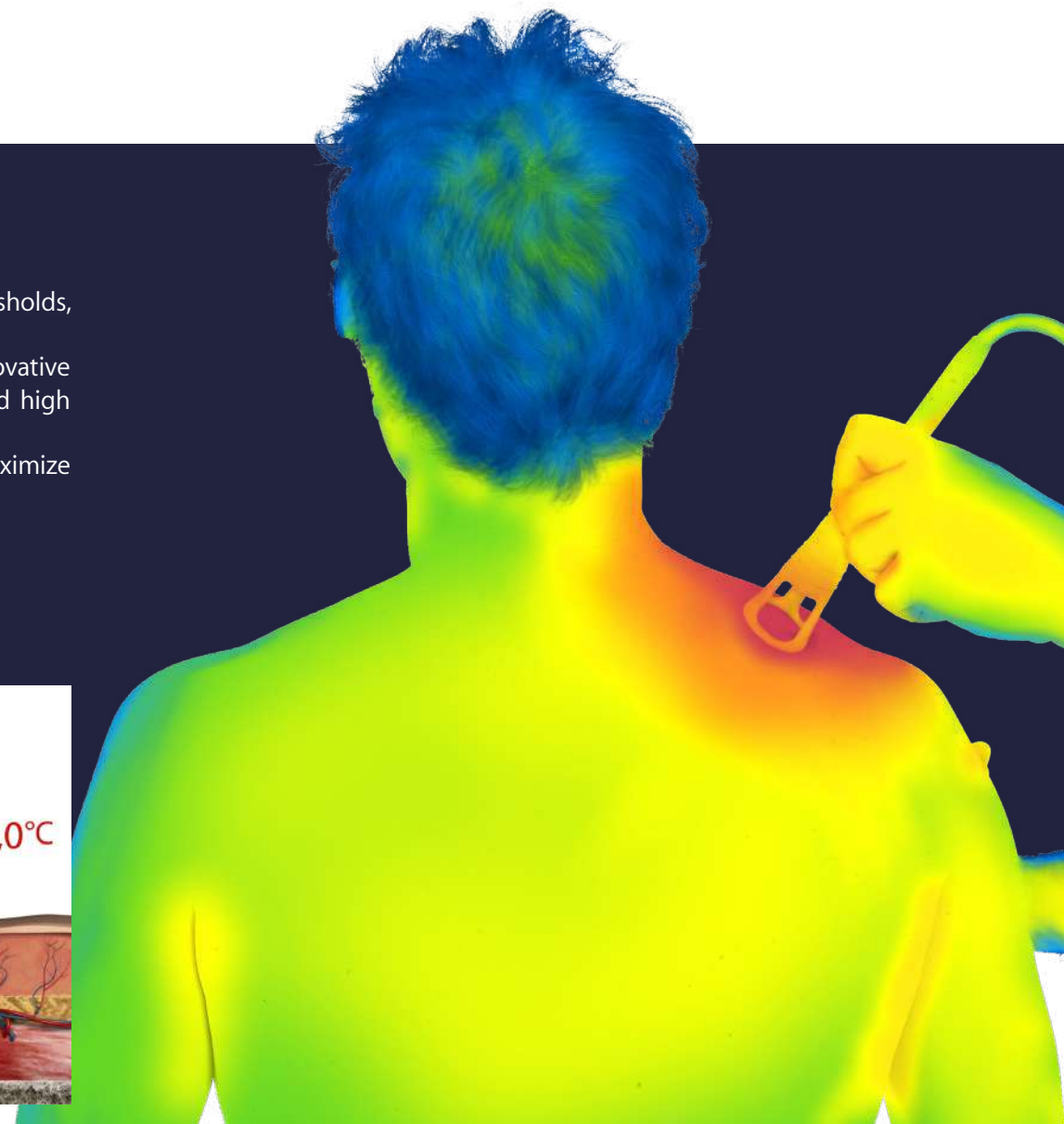
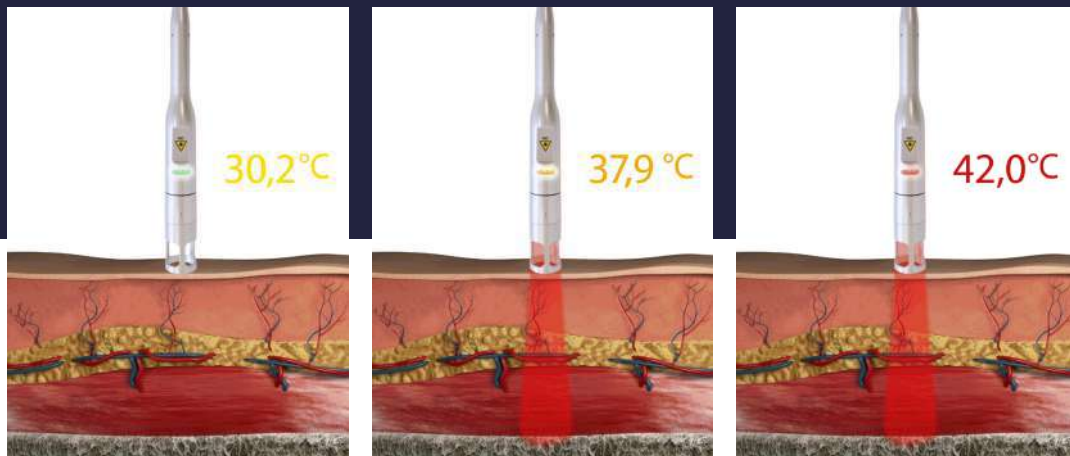



THE FUTURE IS IN YOUR HANDS

Activation and control of the therapy are closely related to the handpiece and the applicators that are used.

For this reason, Mectronic has redesigned ergonomics and redesigned the handpiece functionality for even simpler and more effective therapy.

The innovative ultra-compact and ergonomic **Light Blade** handpiece is born.

Light Blade allows the operator to activate the laser emission directly from the handpiece by simply pressing the new and practical finger switch.

In addition, Light Blade incorporates a polychromatic led system that provides real-time feedback to the operator on the course of the therapy, maximizing control and safety of the therapy session.

AN APPLICATOR FOR EACH TREATMENT

The innovative **Light Blade** handpiece features **patented magnetic technology** and can be expanded with 10 different applicators to satisfy every therapeutic need. Furthermore, Light Blade recognizes the selected applicator and adapts and optimizes the therapy depending on the choice.

Spheric XP compact

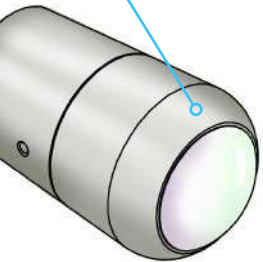

Collimated applicator

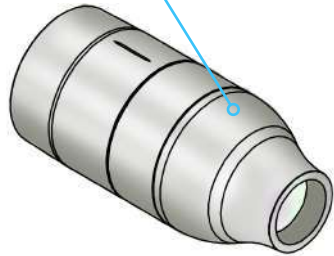

Zoom-Focusable: Variable focus applicator with tissue temperature control system (optional)

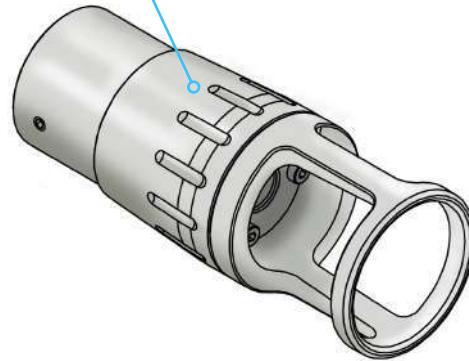

Spheric XP large

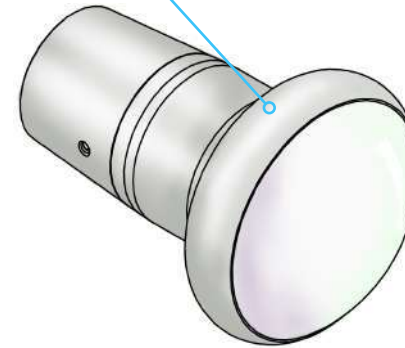

IR compact: Small applicator with tissue temperature control system

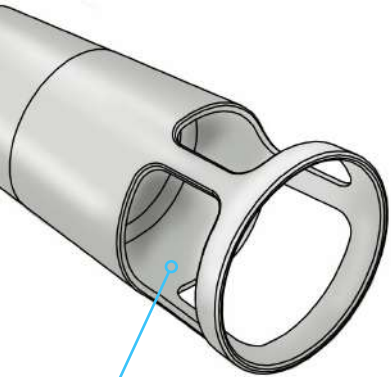
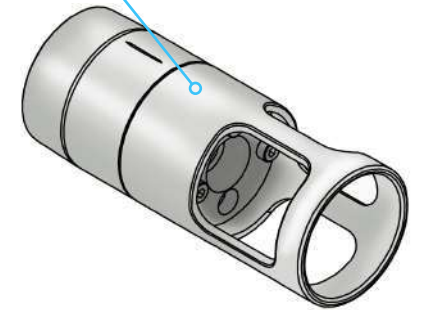

IR large: Large applicator with tissue temperature control system

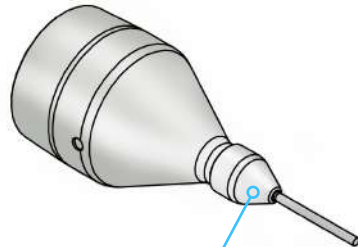

Aurix applicator (optional)

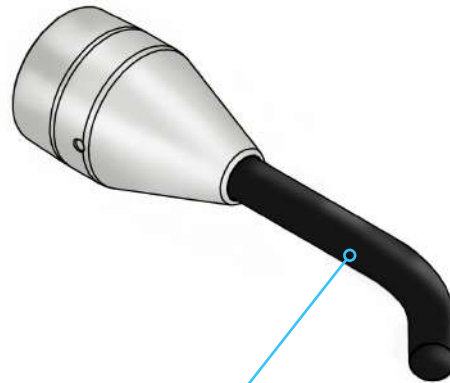

ENT Physio applicator (optional)

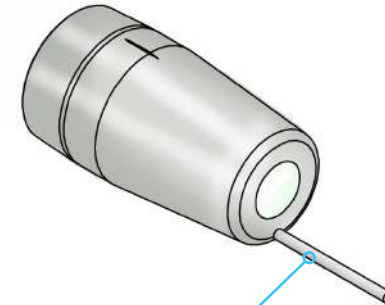

Fixed focus applicator (optional)

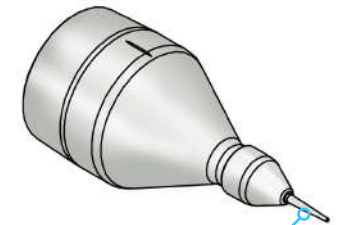

Sapphire applicator (optional)

CHELT FASCIA

CHELT Therapy, thanks to the Spheric XP applicator of the laser module and the Convex Air Boost applicators of the Cryo module, allows to implement both the HELASTM (High Energy Laser Soft Tissue Manipulation) methodology and the CSTM (Cryo Soft Tissue Manipulation) methodology, better known as CHELT Fascia. Spheric XP and Convex Air Boost applicators are designed to exert pressure on the biological tissues and to exploit the clutch that is created during the movement on the tissues. The combination of friction, pressure, cryotherapy and laser energy makes it possible to treat soft tissues and miofascial points in a very effective way, to support and maximize the results of manual therapy.



CHELT PRESS

The CHELT Press system represents an absolute innovation that allows to exert on an entire anatomic district the double action of cryotherapy and compression therapy.

The synergy between pressure and cryotherapy allows a rapid vasoconstriction and a reduction in blood flow, reducing inflammation and edemas and decreasing muscular spasms and metabolic demand, alleviating the pain quickly.

The innovative CHELT Press system, thanks to the possibility to regulate the level of compression during the treatment, allows to increase lymphatic function and to reactivate the microcirculation, supporting the rehabilitation process and accelerating and optimising recovery times.





ADVANCED THERAPY MANAGEMENT

To respond to the needs of the therapist, Mectronic has implemented CHELT Therapy with an innovative, completely new and effective therapy management system. Now the operator will have many features for a highly safe and effective therapy, studied in the smallest detail.



LAMBDA WAVE CREATOR

The revolutionary Lambda Wave Creator has been designed to mix wavelength and create custom emission modes for each of them. It allows you to maximize therapeutic results, choosing from many standard emission modes or creating one manually with a lot of parameters.



TISSUE TARGET SYSTEM

Tissue Target System is a completely new system, which allows adaptation of the therapy, the wavelength and the emission mode, according to the target tissues to be treated - maximizing therapeutic results.



RANGE OF POWER

The endless potential of CHELT Therapy increases with the ability to change the power range. This revolutionary and unique methodology represents the meeting point between low energy laser therapy (LLLT) and high intensity laser therapy.



THERMAL CONTROL

Thanks to advanced IR thermal control, CHELT Therapy can be used for many pathologies concerning the muscular and skeletal system of patients with different phototypes and different tissue types, safely and effectively.

LAMBDA WAVE CREATOR

CHELT Therapy is the innovative synergy between cryotherapy and laser phototherapy which adapts to the characteristics of the patient and the specific pathology. For this reason the devices which deliver CHELT Therapy are equipped with the revolutionary Lambda Wave Creator, the innovative system that allows you to mix wavelength and create custom emission modes for each of them.

With Lambda Wave Creator you will be able to choose and balance different wavelength in order to obtain the perfect mix and perfectly adapt the therapy to the different types of patients and pathologies.

For each wavelength you can also associate the desired emission, according to requirements, creating your own personalized emission that allows you to maximize therapeutic results. It is possible to choose from many standard emission modes, or create one manually with a lot of parameters. The operator can save the created modes and the emission mode mix.

Before now the wavelength mix and the emission modes were fixed and could not be changed, today control is your hands. Thanks to Lambda Wave Creator, therapy is even more flexible and effective.





TISSUE TARGET SYSTEM

CHELT Therapy features many new functions aims at optimizing therapy, making it safe, practical and effective.

The Tissue Target System is a completely new feature which allows the therapy, the wavelength mix, and the emission mode to be adjusted according to the target tissue to be treated.

In fact, the Tissue Target System allows the operator to select the type of tissue with which they want to interact (nervous, osteoarticular, tendon-ligamentous, muscular, connective-myofascial and epithelial) and the physico-chemical effect they want to generate. Once the desired configuration is set, the therapy will adapt to the required requirements. This way it is possible to manage the best treatment based on specific needs of the patient and the pathology.

TEMPERATURE CONTROL SYSTEM

Another new feature of CHELT Therapy is the control of the temperature of tissues in real-time both during the THEAL laser treatment and during the cryotherapy treatment. It is possible to treat pathologies of the musculoskeletal apparatus of different types of patients with different phototypes in the various pathological phases (acute, subacute and chronic) in a safe way, thanks to the modulation of energy and to the control in real time of the tissue temperature.

The operator has the possibility to set one or two thermal thresholds, which will be monitored thanks to the constant feedback of the infrared thermal sensor present in some applicators.

All this is possible thanks to the advanced system designed and patented by Mectronic: the Temperature Control System.

This innovation maximizes the therapeutic results and guarantees full control of the therapy in total safety, making CHELT Therapy the perfect methodic to meet the needs of operators and patients.





AN UNPRECEDENTED RANGE OF POWERS

Power allows you to transfer energy to biological tissues in time necessary to get beneficial effects.

CHLT Therapy is the innovative therapeutic method that expands the phototherapy application possibilities by providing a wide range of power values, representing the meeting point for Low Level Laser Therapy (LLLT) and High Level Laser Therapy (HLLT).

Thanks to the innovative **StarLight Pentax** and **Starlight Ennax** laser heads, and thanks to the innovative emission control system, CHLT Therapy allows laser light to be delivered with different mixes of wavelengths and powers ranging from 10 mW to dozens watts.



A TECHNOLOGICAL HEART

CHELT Therapy incorporates an innovative multifunctional core, featuring a new software and a new user interface, to offer operator greater convenience.

Equipped with multiple features and customizations, **MecOS 4.0 OMNIA** is the most advanced, comprehensive and intuitive control software.

INTERACTIVE PATHOLOGIES

CHELT Therapy features a pathology library with over 90 therapeutic protocols, subdivided by phase, for the treatment of the most common pathologies. The therapeutic protocols in the library have been studied according to the different composition of tissues, and adapt according to the phototype and the age of the patients to be treated.

It also features specific therapeutic protocols to obtain the five main effects of CHELT Therapy: Biostimulant, Analgesic, Anti-inflammatory, Anti-edema and Decontracting. When every mode is selected, the operator is guided through the set up of the most suitable treatment to achieve the desired effect.

Thanks to the interactive VAS Scale, integrated into the device, CHELT Therapy allows the analgesic protocol to be adapted, setting the level of pain of the patient and monitoring it during the therapy.

Reference **treatment videos** are supplied to help explain the treatment.





STATE OF PAIN

Thanks to the complete pathological library of CHELT Therapy, it is possible to select the therapeutic protocol based on the condition of the disease: Acute, SubAcute and Chronic. For each selected protocol, you will be shown, via pictures and videos, how to intervene on the area to be treated. Additionally, the therapist can monitor the patient's level of pain thanks to the VAS Scale, automatically adjusting the parameters of the therapy.



TYPE OF TISSUE

The different therapeutic protocols have been studied in such a way as to take into account differences in tissue composition. For this reason, the operator can select the age range to which the person to be treated belongs. In addition, you will be asked to indicate the somatotype of the patient by choosing between Endo, Meso and Ecto.



CATEGORIES OF PHOTOTYPE

Another important factor for proper and safe therapy is the patient's phototype. The melanin present in the skin is a chromophore that absorbs part of the laser radiation; For this reason, CHELT Therapy allows you to set the patient's phototype to be treated by automatically adjusting the parameters of the therapeutic protocol to make it safe, effective and performing.



CALCULATION OF THE AREA

To ensure the correct therapeutic dose and greater control of the energy transferred to tissues, CHELT Therapy provides a simple and practical tool for calculating the precise size of the area to be treated.

CUSTOM PROTOCOLS

CHELT Therapy has a simple and intuitive editor for creating custom protocols, allowing you to build protocols with up to 5 distinct phases by defining all the parameters of the therapy. Protocols are easily customizable through the innovative and practical graphical interface of the editor, allowing you to simultaneously monitor the values of all phases and change them as needed.





CHELT 30

30 W

650 nm - 2W	■ ■
810 nm - 8 W	■ ■ ■ ■ ■ ■ ■ ■
980 nm - 10 W	■ ■ ■ ■ ■ ■ ■ ■ ■ ■
1064 nm - 10 W	■ ■ ■ ■ ■ ■ ■ ■ ■ ■



CHELT 50

50 W

650 nm - 2W	■ ■
780 nm - 10 W	■ ■ ■ ■ ■ ■ ■ ■ ■ ■
810 nm - 8 W	■ ■ ■ ■ ■ ■ ■ ■
905 nm - 10 W	■ ■ ■ ■ ■ ■ ■ ■ ■ ■
980 nm - 10 W	■ ■ ■ ■ ■ ■ ■ ■ ■ ■
1064 nm - 10 W	■ ■ ■ ■ ■ ■ ■ ■ ■ ■

CHELT 90

90 W

450 nm - 10W	■ ■ ■ ■ ■ ■ ■ ■ ■ ■
650 nm - 2W	■ ■
780 nm - 15 W	■ ■ ■ ■ ■ ■ ■ ■ ■ ■ ■ ■ ■ ■ ■ ■
810 nm - 15 W	■ ■ ■ ■ ■ ■ ■ ■ ■ ■ ■ ■ ■ ■ ■ ■
905 nm - 15 W	■ ■ ■ ■ ■ ■ ■ ■ ■ ■ ■ ■ ■ ■ ■ ■
980 nm - 15 W	■ ■ ■ ■ ■ ■ ■ ■ ■ ■ ■ ■ ■ ■ ■ ■
1064 nm - 15 W	■ ■ ■ ■ ■ ■ ■ ■ ■ ■ ■ ■ ■ ■ ■ ■
1210 nm - 5 W	■ ■ ■ ■ ■



TECHNICAL SPECIFICATIONS OF CHELT THERAPY PRODUCTS

Technology	Mectronic's own MecOS 4.0 OMNIA Real-Time Operating System
Guide Light	650 nm - 3mW
Emission	Continuous (CW), Pulsed, Superpulsed, E ² C (patented stochastic mode), AntInf, HPM and Dimmer
Personal Emission	Lambda Wave Creator
Operation Mode	Manual, Single Pulse, Burst and Custom mode
Special Modes	Joule Mode, Timer Mode, Trigger Point Mode, Tissue Target System and Temperature Control mode
Effects Mode	5 specific emission modes to maximise the 5 main effects of CHELT Therapy: Biostimulant, Analgesic, Anti-inflammatory, Anti-edema, and Decontracting
Pathologies	Over 90 therapeutic protocols with interactive illustrations and protocols sub-divided by phase
Calibration	Graphic and acoustic control system for laser emission at handpiece exit in accordance with norm CEI EN 60825-1
Display	Full HD Colour TFT 15,6" display with capacitive Touch Screen
Supply	100 ÷ 240V 50 ÷ 60Hz
Absorption	250 VA
Laser Class	IV



Beam Divergence	25°
Puls Width	1 - 1000 ms
IP Classification	IPX0 device IPX0 handpiece IPX4 pneumatic footswitch
Terms operating	0 ÷ 30°C 30 ÷ 75% humidity non-condensing 700 ÷ 1060 hPa
Terms transportation and storage	-10 ÷ 60°C 10 ÷ 100% humidity non-condensing 500 ÷ 1060 hPa
EMP	Maximal emission permit on skin 5600W/m ²
EMP	Maximal emission permit on cornea 9W/m ²
DNRO	Nominal Distance of Ocular Risk: 10,5m (30W); 13,5m (50W); 18m (92W)
Conformity	IEC/EC 60601-1; IEC 60601-1-2; IEC 60601-2-22
Certification	CE0051
Directive 93/42	Classification IIb
Dimensions and Weight	400 x 823 x 1398 mm - 60 kg



MECTRONIC ADVANCED MEDICAL ACADEMY

Mectronic launches Mectronic Advanced Medical Academy, a facility devoted entirely to the research, development and dissemination of innovative therapeutic methods.

Thanks to Mectronic Advanced Medical Academy, the formation and dissemination of knowledge will reach levels never seen before.



Mectronic presents the new training plan, designed to gather all the events dedicated to Mectronic therapies. The purpose is to divulge the most advanced methods to keep knowledge up to date.

Mectronic Advanced Medical Academy organizes training and updating training sessions held by industry experts and professionals around the world, in Italy and abroad.

Visit the Courses page at www.mectronicmedicale.com and take part in the course that best suits your needs.





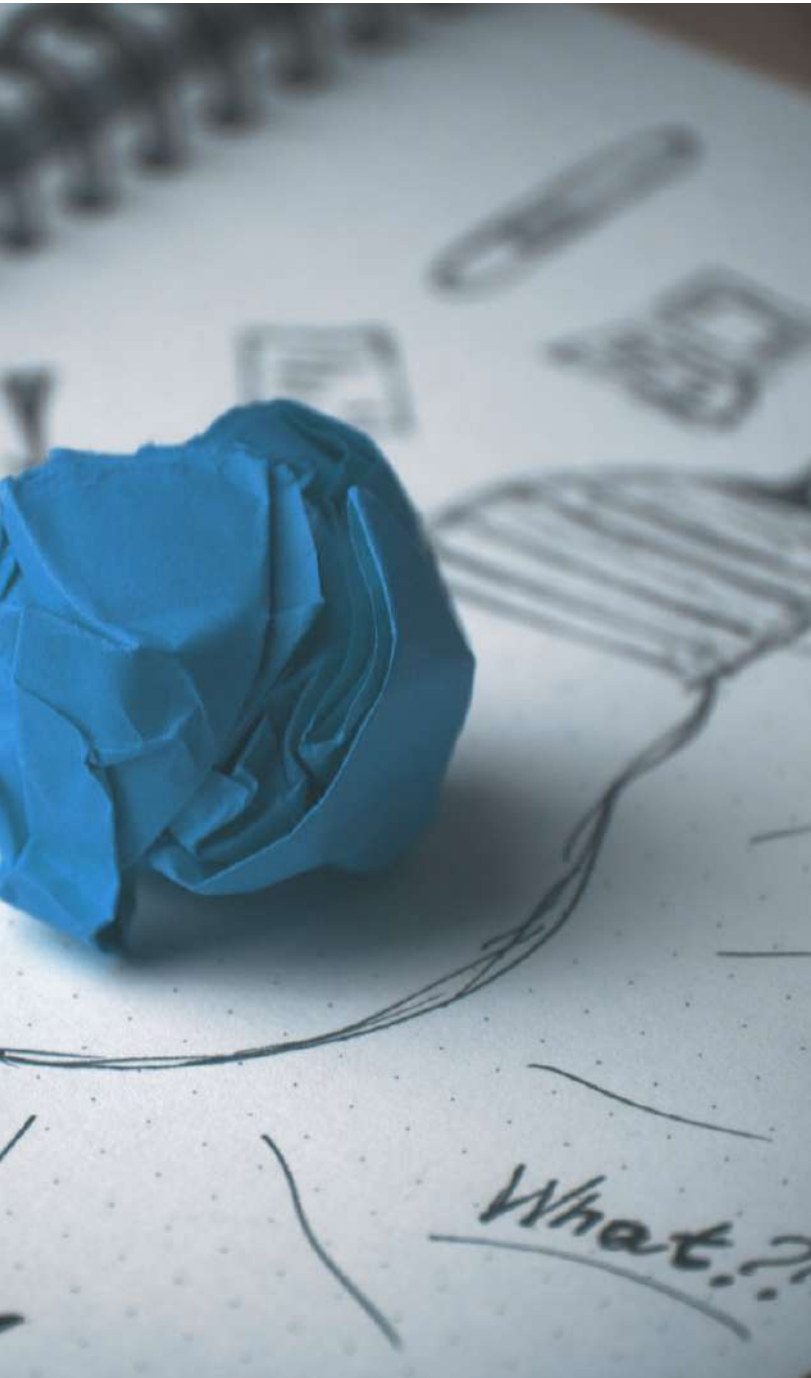

BIBLIOGRAPHY

1. P.F Parra, I laser ad Argon e Neodimio Yag nella pratica clinica, Torino, Edizioni libreria cortina, 1991
2. Castellacci E., Ciuti F., Conforti M., Di Domenica F., Il Nd:YAG e La terapia Laser ad Alta Energia, Bologna, Edizioni Martina, 2003
3. Magni Luca, Laser therapy and basketball 2001, Laser & Technology, Giugno 2002, 24-29
4. Miglio D., Use of high power neodymium yag laser and fcz laser in the treatment of pubalgia, Laser & Technology, Maggio-Dicembre 2001, 46-48
5. Benedini M., Conforti M., High Power Neodimium-Yag Laser therapy in the treatment of muscle lesions without hematomas in athletes, Laser & Technology, Maggio-Dicembre 2001, 49-51
6. Gualtieri E., Laser Treatment of Muscle Lesions, Laser & Technology, Gennaio-Agosto 2003, 35-39
7. Clavel D.H., Laser De Alta Potencia, AKD, 2006, 2-7
8. Clavel D.H., Facundo C., Leoni C.A., Terapia FP3 (Laser de Alta Potencia) en lesiones musculares, 2008, 15-20
9. Tina Karu: "Ten Lectures on Basic Science of Lasertherapy" Prima Books AB Grängesberg, Sweden 2007
10. "Mechanisms of low level light therapy" (2006) M. Hamblin, T. Demidova
11. "Multiple Roles of Cytochrome c Oxidase in Mammalian Cells Under Action of Red and IR-A Radiation" (2010) T. I. Karu
12. "Re-evaluation of the near infrared spectra of mitochondrial cytochrome c oxidase: Implications for non invasive in vivo monitoring of tissues" (G.Mason, P. Nicholls, E. Cooper – 2014)
13. "Studies into the Action Specifics of a Pulsed GaAlAs Laser ($\lambda=820\text{nm}$) on a Cell Culture" (2001) T. Karu
14. "Low-Level Laser Therapy Enhances Wound Healing in Diabetic Rats: A Comparison of Different Lasers" Farouk A.H. Al-Watban

SCIENTIFIC STUDIES

15. Casale R., Damiani C., Maestri R., Wells C.D., Pain and electrophysiological parameters are improved by combined 830-1064 high-intensity LASER in symptomatic carpal tunnel syndrome versus Transcutaneous Electrical Nerve Stimulation, European Journal of Physical and Rehabilitation Medicine, 2012, 48:1-2
16. Notarnicola A., Forcignanò M., Fiore A., Moretti B., "CHELT Therapy in the Treatment of Chronic Insertional Achilles Tendinopathy", UO di Ortopedia e Traumatologia, Policlinico di Bari, Dipartimento di Neuroscienze e Organi di Senso, Università degli Studi di Bari, 2012
17. "Tri-length laser therapy associated to tecar therapy in the treatment of low-back pain in adults: a preliminary report of a prospective case series." Osti R, Pari C, Salvatori G, Massari L. - Epub 2014 Nov 7
18. "Temperature controlled high energy adjustable multi-mode emission laser therapy (THEAL) for the treatment of lower back pain: clinical efficacy and comparison of different wavelengths" Notarnicola Angela, Covelli Ilaria, Fiore Alessandra, Fari Giacomo, Megna Marisa, Moretti Biagio (Bari)
19. 'Short-term effect of Shockwave Therapy, Temperature controlled High Energy Adjustable multi-mode emission Laser (THEAL Therapy) or stretching in Dupuytren's disease: a prospective randomized clinical trial.



Follow us on:



MECTRONIC MEDICALE SRL

Via Orio al Serio, 15
24050 Grassobbio
Bergamo (Italia)

Ph +39 035656080
Fax +39 035657361
www.mectronicmedicale.com
info@mectronicmedicale.it